



Sincera Sistemi[®]

Sigilla la tua qualità in modo semplice e veloce
Seal your quality in a simple and fast way



SINCERA 1

SINCERASISTEMI.IT

SINCERA 1

IT MACCHINA CERATRICE MANUALE	EN MANUAL WAXING MACHINE	ES MÁQUINA LACRADORA MANUAL	FR MACHINE CIREUSE MANUELLE
Sincera 1, il modello manuale, permette di sigillare una bottiglia alla volta, da un formato minimo di 0,75 lt fino ad un massimo di 5 lt. Grazie ad un comodo termostato manuale è possibile regolare la temperatura per lo scioglimento della cera nella vaschetta. La macchina, inoltre, è dotata di un motore per la rotazione della bottiglia sui rulli e di una ventola per un più rapido raffreddamento. In caso di cambio colore, la vaschetta è facilmente sostituibile.	Sincera 1, the manual model, can handle one bottle at a time, from a minimum size of 0.75 l. up to a maximum of 5 l. Thanks to a handy manual thermostat, it is possible to set the temperature for melting wax inside the tank. The machine, moreover, is equipped with a motor for bottle rotation on the rollers and a fan for faster cooling. In the event of colour change, the tank can be easily replaced.	Sincera 1, el modelo manual, permite lacrar una botella a la vez, de un tamaño mínimo de 0,75 l hasta un máximo de 5 l. Gracias a un práctico termostato manual, se puede regular la temperatura de fusión del lacre dentro de la cubeta. La máquina, además, está equipada con un motor para la rotación de la botella sobre los rodillos y con un ventilador para un enfriamiento más rápido. En caso de cambio color, la cubeta puede reemplazarse fácilmente.	Sincera 1, le modèle manuel, permet de cirer une bouteille à la fois, d'une taille minimale de 0,75 l jusqu'à un maximum de 5 l. Grâce à un thermostat manuel pratique, il est possible de régler la température de fusion de la cire dans le bac. La machine est également équipée d'un moteur pour faire tourner la bouteille sur les rouleaux et d'un ventilateur pour accélérer le refroidissement. En cas de changement de couleur, le bac peut être facilement remplacé.

DOTAZIONE DI SERIE	STANDARD EQUIPMENT	EQUIPO ESTANDAR	EQUIPMENT STANDARD
Nr. 1 vaschetta in acciaio inox Nr. 1 kit di supporti bottiglie da 0,75 a 5,0 lt* Nr. 1 sistema di raffreddamento	No. 1 stainless steel tray No. 1 bottle supports kit from 0.75 l to 5l* Nr. 1 fan cooling system	Nr. 1 cubeta en acero inoxidable Nr. 1 juego de soportes botellas de 0.75 hasta 5 l* Nr. 1 sistema de enfriamiento	Nr. 1 bac en acier inoxydable Nr. 1 jeu des supports bouteilles de 0,75 à 5lt* Nr. 1 système de ventilation
* <i>Bordolese o Borgognotta</i>	* <i>Bordolese o Borgognotta</i>	* <i>Bordelesa o Borgoña</i>	* <i>Bordelaise ou Bourgogne</i>

ACCESSORI	ACCESSORIES	ACCESORIOS	ACCESSOIRES
Regolazione in altezza della vaschetta	Tray height regulation system	Reglaje en altura de la cubeta	Reglage en hauteur du bac
Timbro in ottone personalizzato	Personalised brass stamp	Sello personalizado en latón	Cachet personnalisé en laiton
Vasca di ricambio	Replacement Tray	Cubeta de repuesto	Bac de remplacement
Kit supporti bottiglie	Bottle supports kit	Juego de soportes botellas	Jeu de supports bouteilles
Carrello	Trolley	Carro	Chariot

DATI TECNICI | TECHNICAL DATA | DATOS TÉCNICOS | DONNÉES TECHNIQUES

TENSIONE D'ALIMENTAZIONE SUPPLY VOLTAGE TENSIÓN DE ALIMENTACIÓN TENSION D'ALIMENTATION	230 V - 50Hz/60Hz
POTENZA TOTALE ASSORBITA TOTAL POWER CONSUMPTION POTENCIA TOTAL ABSORBIDA PUISSANCE TOTALE ABSORBÉE	800 W / 3,5 A
NUMERO BOTTIGLIE NUMBER OF BOTTLES NÚMERO DE BOTELLAS NOMBRE DE BOUTEILLES	1
BOTTIGLIE UTILIZZABILI USABLE BOTTLES BOTELLAS UTILIZABLES BOUTEILLES UTILISABLES	0.75 LT - 5/6 LT MIN. Ø ± 70 MM - MAX. Ø ± 160 MM
TEMPERATURA UTILIZZO CERA WORKING TEMPERATURE OF WAX TEMPERATURA DE USO DEL LACRE TEMPÉRATURE D'UTILISATION DE LA CIRE	± 90°C
QUANTITÀ CERA QUANTITY OF WAX CANTIDAD DE LACRE QUANTITÉ DE CIRE	3 KG
PRODUZIONE MASSIMA MAXIMUM PRODUCTION PRODUCCIÓN MÁXIMA PRODUCTION MAXIMALE	± 100 b/h

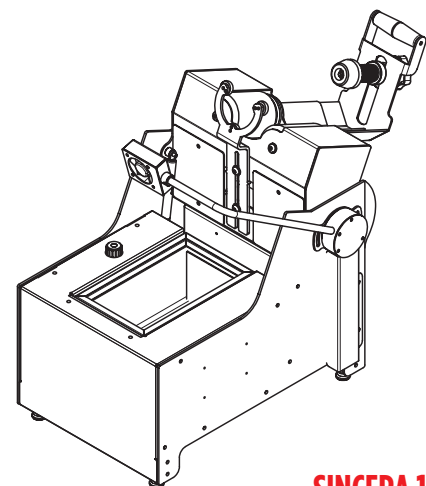

SINCERA 1

PRODUZIONE ANNUA | ANNUAL PRODUCTION | PRODUCCION ANUAL | PRODUCTION ANNUELLE

	0-2000	2000-5000	5000-20000	20000-100000	100000-....
SINCERA M	✓	✗	✗	✗	✗
SINCERA 1	✓	!	✗	✗	✗
SINCERA 2	!	✓	✓	!	✗
SINCERA 4	✗	!	✓	✓	!
SINCERA SL14	✗	✗	✗	!	✓

DIMENSIONI | DIMENSIONS | MEDIDAS | DIMENSIONS

H 650 mm x l 480 mm x L 770 mm

PESO | WEIGHT | PESO | POIDS

± 40 kg



CARATTERISTICHE FEATURES CARACTERÍSTICAS CARACTÉRISTIQUES	TIMBRATURA AUTOMATICA AUTOMATIC STAMPING ESTAMPADO AUTOMÁTICO ESTAMPILLAGE AUTOMATIQUE	REGOLAZIONE VASCHETTA TRAY HEIGHT REGULATION SYSTEM REGLAJE EN ALTURA DE LA CUBETA REGLAGE EN HAUTEUR DU BAC	CAMBIO VASCHETTA TRAY CHANGE CAMBIO CUBETA CHANGEMENT DU BAC	ALTRI FORMATI (NON ROTONDI) OTHER FORMATS (NOT ROUNDED) OTROS TAMAÑOS (NO REDONDOS) AUTRES FORMATS (NON RONDS)	ACCENSIONE PROGRAMMABILE PROGRAMMABLE POWER-ON ARRANQUE PROGRAMMABLE DEMARRAGE PROGRAMMABLE
SINCERA M	✗	✗	✓	✓	✗
SINCERA 1	✗	✓	✓	✗	✗
SINCERA 2	✓	✓	✓	✓	✓
SINCERA 4	✓	✓	✓	✓	✓
SINCERA SL14	✓	✓	✓	✓	✓

